

REME Möbelbeschläge GmbH
Industriestraße 48
D-33161 Hövelhof

+49 (0) 5257-9492920

www.reme-gmbh.de

[instagram.com/reme_gmbh](https://www.instagram.com/reme_gmbh)

[facebook.com/reme.job](https://www.facebook.com/reme.job)

REME

Leadership quality for furniture

Company

As a 3rd generation family business, acting responsibly is an integral part of our corporate culture. We take responsibility for our employees, for the quality of our products and for the impact of our business activities on society and the environment – with the aim of shaping a better future.

Quality assurance

To ensure that machines and equipment in our plants meet our high-quality standards, we develop many of them by ourselves. With uniform inspection specifications and automated inspection stations, we manufacture large quantities in consistently high quality. We use a wide range of measuring equipment for our quality control – from simple callipers to state-of-the-art 3D measuring arms. Because we know how tough everyday furniture can be, we continuously simulate rigorous endurance and stress tests on our slides in our own test lab.

Energy Management

The DIN EN ISO 50001 certification confirms that REME meets all the requirements of this standard and constantly controls and optimizes energy consumption. On the one hand, the improvements reduce energy consumption and production costs, on the other hand, they lead to lower CO2 emissions and thus reduce global climate change. With this certification, we commit ourselves to the continuous optimization of energy requirements and the resource-conserving use of non-renewable energy sources both in the production plants and in administration. Through this commitment, we assume responsibility for future generations as well as for environmental and climate protection.

Sustainability

For REME, sustainability is the core prerequisite for long-term economic success. It creates the conditions for our company to increase its acceptance in society and to secure its future – and thus also the jobs of its employees – in the long term. Sustainable management therefore requires a balance between several aspects: Environmental protection, occupational safety, energy management, product innovation, quality assurance, employee care, customer care, plant maintenance, etc.

Last but not least, our employees play an important role in our economic success, which is why, especially as a family-owned company, we strive to create framework conditions for our employees that help them to balance their professional and private needs as well as possible. With our company health management, we strive to maintain the satisfaction of our employees. Our company suggestion scheme and improvement management promote new ideas and provide incentives for the internal optimization of processes.

Icons

To give you a quick overview of what our products can do, we have developed icons that symbolise important features and functions.



Single Extension



Full Extension



Loading capacity up to 30 kg



Loading capacity up to 25 kg



Push-to-Open



Soft-close



Self-close



Installation width 23 mm



Peanut® connection technology



Single Extension PERFECT PEANUT®

Soft-close _____ Page 28

Push-to-Open _____ Page 32

Product

The star-shaped geometry of the PERFECT PEANUT® single extension skilfully absorbs incorrect loads. The overlapping of the star-shaped area ensures high rigidity, which also has a positive effect on the running properties. The PEANUT® connection technology also allows the drawer runner to be **mounted without tools**. PERFECT PEANUT® fulfils all functional requirements for wooden drawers in living and sleeping areas. PERFECT PEANUT® is optionally available with soft-close and with push-to-open.

PEANUT® connection technology

The PEANUT® is an invisible connector which allows the PERFECT slide to be mounted quickly and easily without tools. The PEANUT® is made of reinforced glass fibre nylon, which ensures a high clamping force when inserted into the cabinet wall. The PEANUT® head is specifically designed to maximise ease of assembly and joint strength. The PERFECT concealed slides can thus be installed quickly, easily and without tools.

Single Extension PERFECT PEANUT®

Soft-close and plug-on assembly



Installation Dimensions

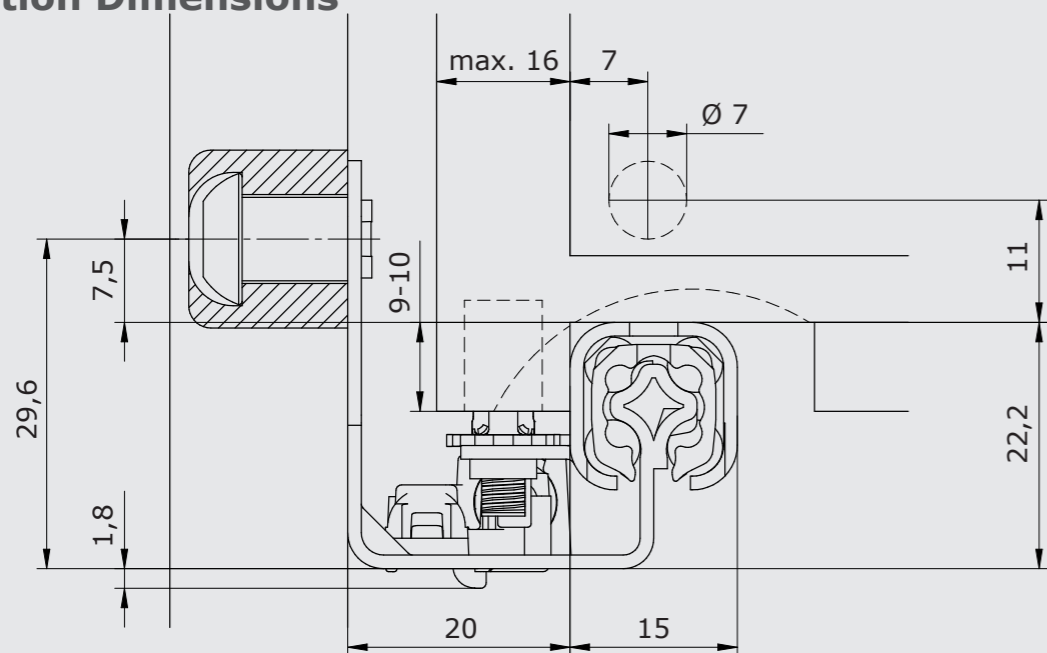

Length and hole pattern of the cabinet runner

Length cabinet runner A	214	246	278	310	342
Peanut hole distance B	160	192	224	256	288

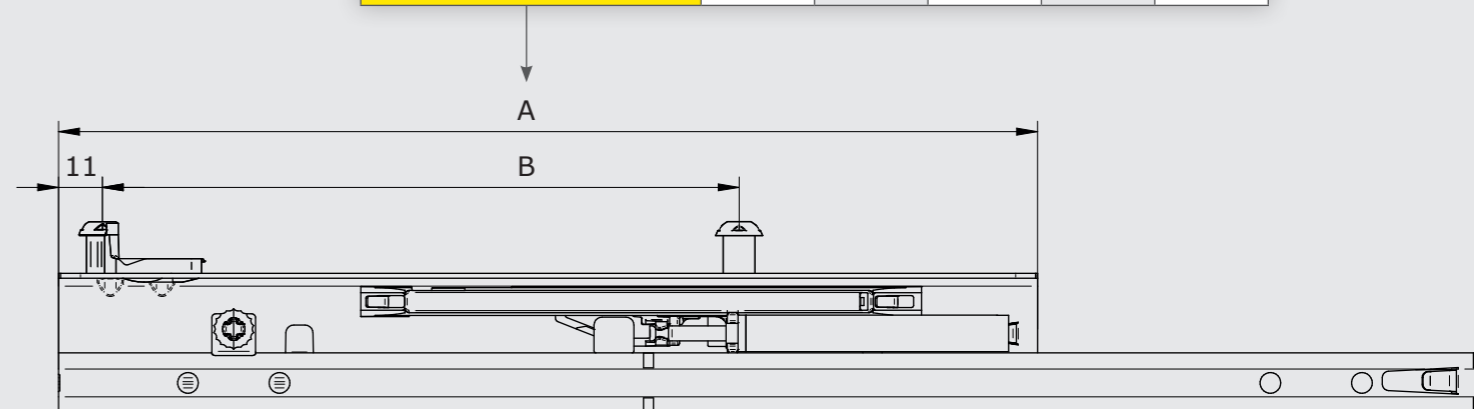

Features

- Star-shaped profile
- Loading capacity up to 25 kg
- Lengths from 250 to 550 mm
- Quick plug-on assembly of the drawer
- Stepless height adjustment
- High tracking stability with smooth running
- Perfect height and lateral stability
- With PEANUT® connecting fittings
- Quick and easy assembly
- With soft-close

Drillings and cut-outs

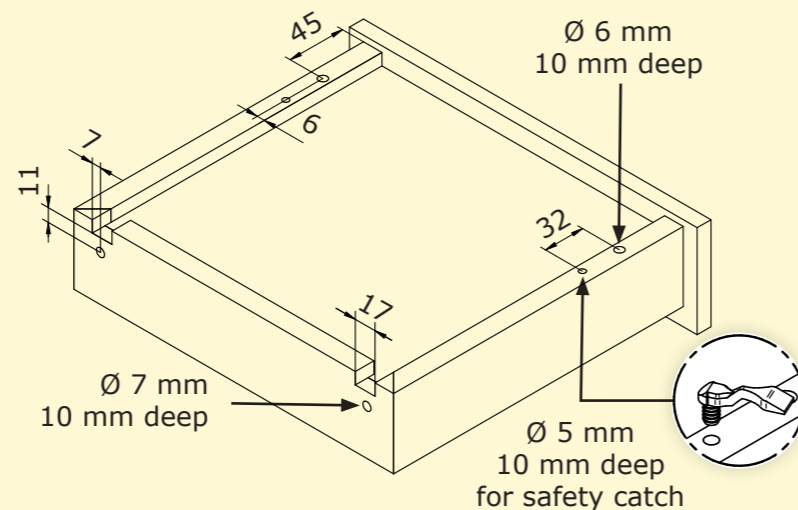

Milling in the cabinet

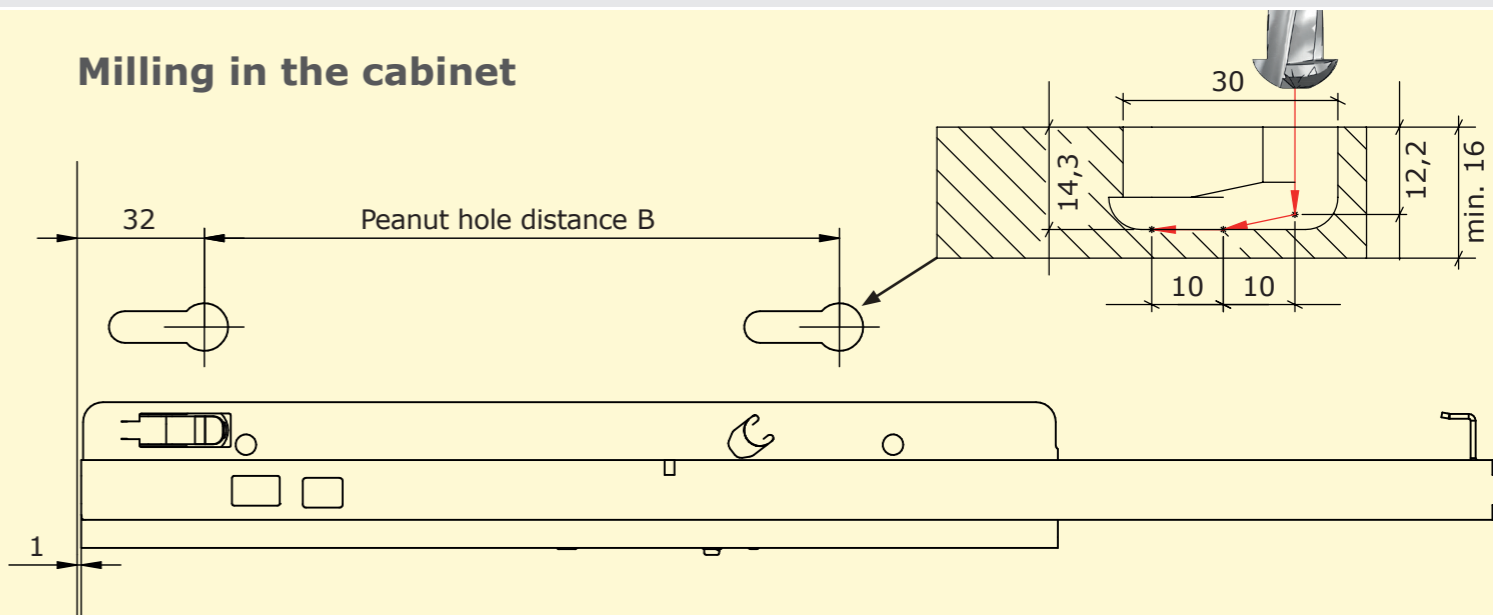

Drawer length in mm	Cabinet runner in mm	Drawer runner in mm	Soft-close	Runners/Box	Boxes/Pallet maximum	Pieces/Pallet maximum	Weight/Pallet maximum	Order number left side	Order number right side
250	214	260	x	30	45	1350	468	3212502019000	3222502019000
300	246	310	x	30	35	1050	421	3213002019000	3223002019000
350	246	360	x	30	35	1050	443	3213502019000	3223502019000
400	278	410	x	24	42	1008	489	3214002019000	3224002019000
450	310	460	x	24	42	1008	542	3214502019000	3224502019000
500	342	510	x	24	30	720	420	3215002019000	3225002019000
550	342	560	x	24	30	720	435	3215502019000	3225502019000



Installation Dimensions

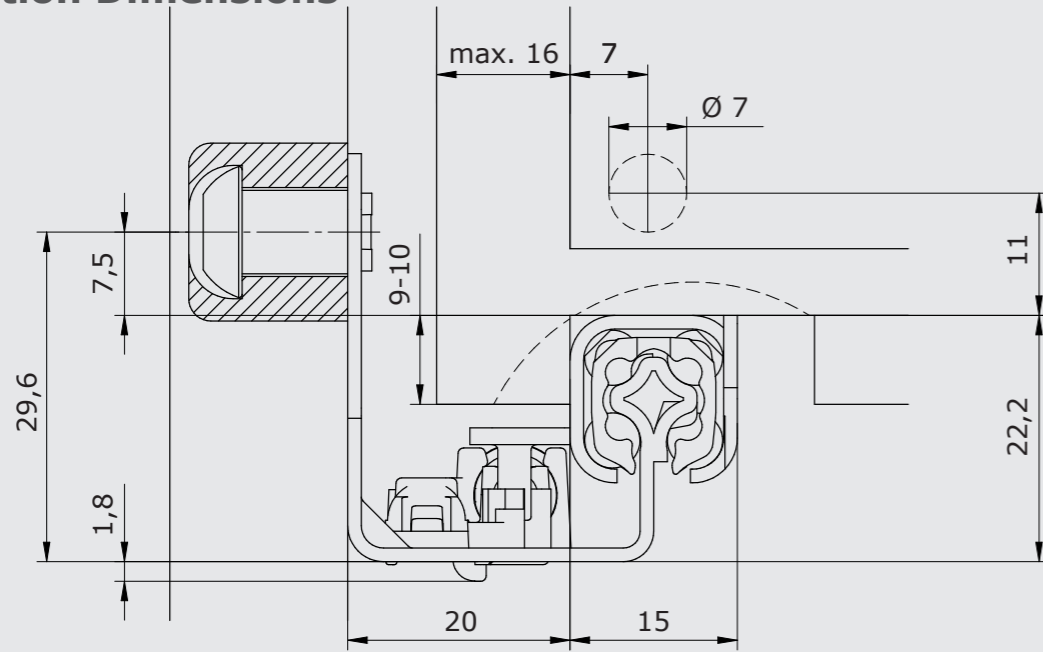

Length and hole pattern of the cabinet runner

Length cabinet runner A	214	246	278	310	342
Peanut hole distance B	160	192	224	256	288

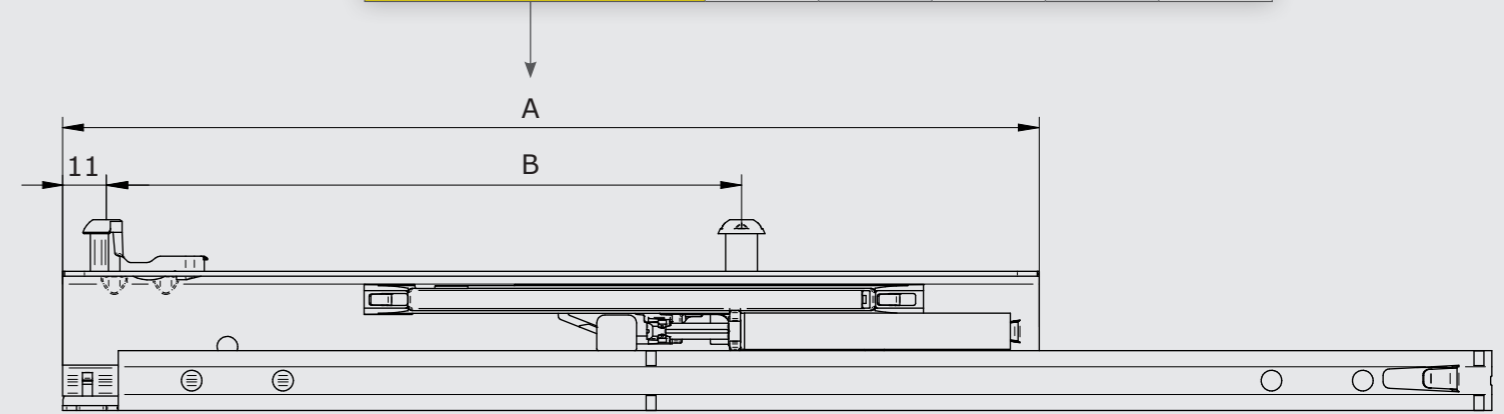

Features

- Star-shaped profile
- Loading capacity up to 25 kg
- Lengths from 250 to 550 mm
- Stepless height adjustment
- High tracking stability with smooth running
- Perfect height and lateral stability
- With PEANUT® connecting fittings
- Quick and easy assembly of the drawer
- With soft-close
- Optionally with 1D or 2D coupling

Coupling technology

The types of couplings make the mounting and demounting of drawers quick and easy. All in one: safety catch, coupling and alignment. Available either as 1D (height adjustment), or 2D (height and side adjustment). A precise joint pattern can be achieved quickly, easily and without tools.

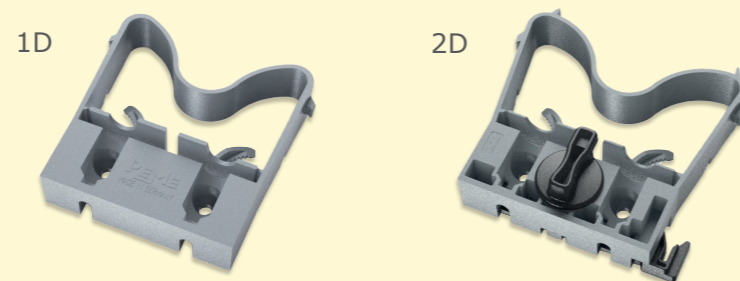

Milling in the cabinet

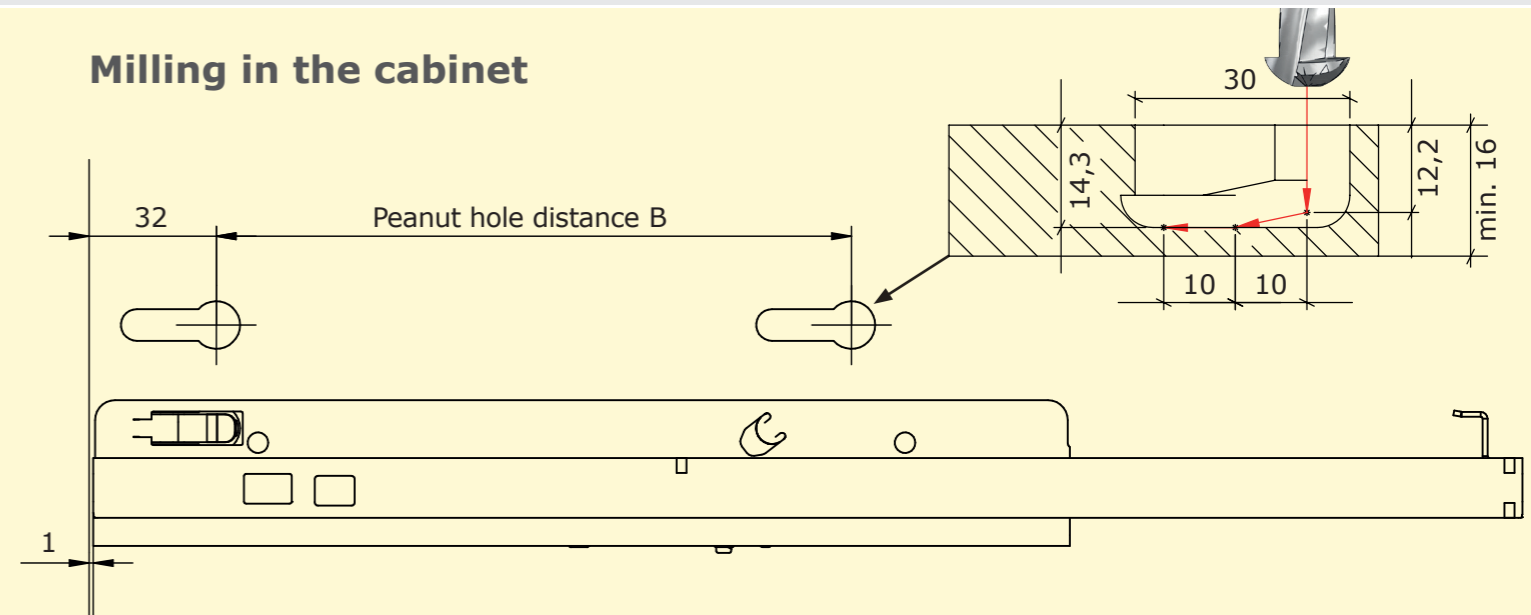

Drawer length in mm	Cabinet runner in mm	Drawer runner in mm	Soft-close	Runners/Box	Boxes/Pallet maximum	Pieces/Pallet maximum	Weight/Pallet maximum	Order number left side	Order number right side
250	214	260	x	30	45	1350	468	3212502019200	3222502019100
300	246	310	x	30	35	1050	421	3213002019200	3223002019100
350	246	360	x	30	35	1050	443	3213502019200	3223502019100
400	278	410	x	24	42	1008	489	3214002019200	3224002019100
450	310	460	x	24	42	1008	542	3214502019200	3224502019100
500	342	510	x	24	30	720	420	3215002019200	3225002019100
550	342	560	x	24	30	720	435	3215502019200	3225502019100

Single Extension PERFECT PEANUT®

Push-to-Open and plug-on assembly



Installation Dimensions

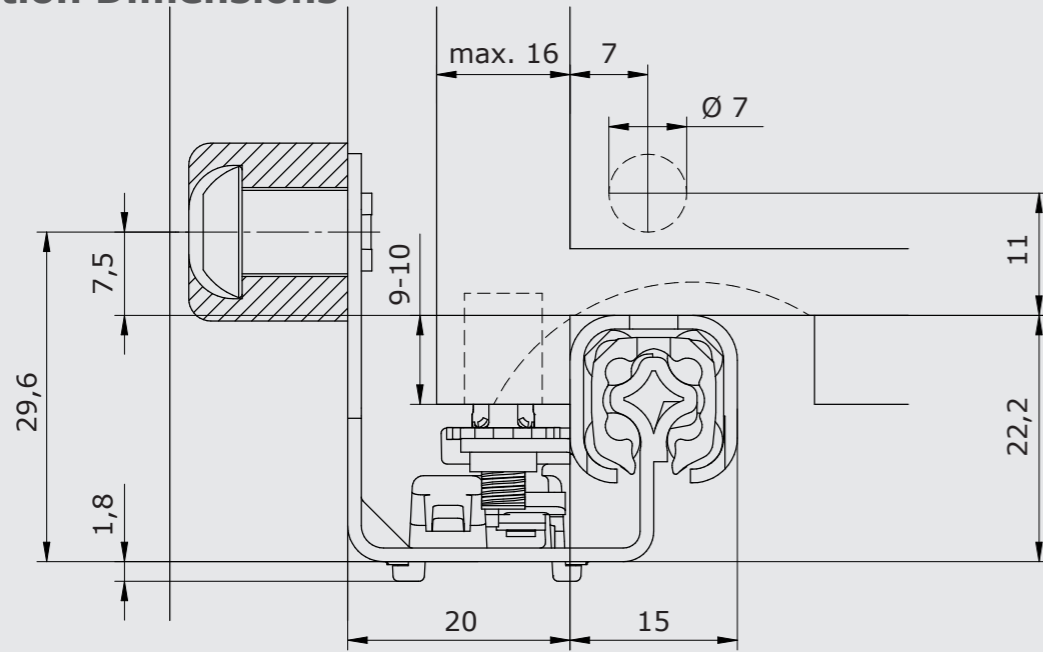

Length and hole pattern of the cabinet runner

Length cabinet runner A	214	246	278	310	342
Peanut hole distance B	160	192	224	256	288

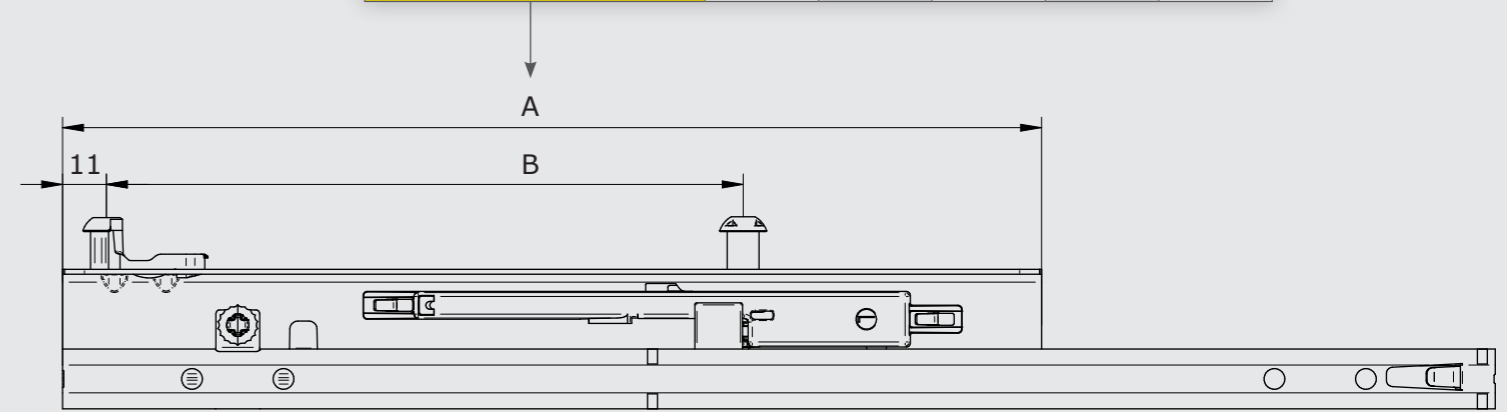

Features

- Star-shaped profile
- Loading capacity up to 25 kg
- Lengths from 250 to 550 mm
- Quick plug-on assembly of the drawer
- Stepless height adjustment
- High tracking stability with smooth running
- Perfect height and lateral stability
- With PEANUT® connecting fittings
- Quick and easy assembly
- Trigger path/reveal gap = 3 mm
- With push-to-open

Drillings and cut-outs

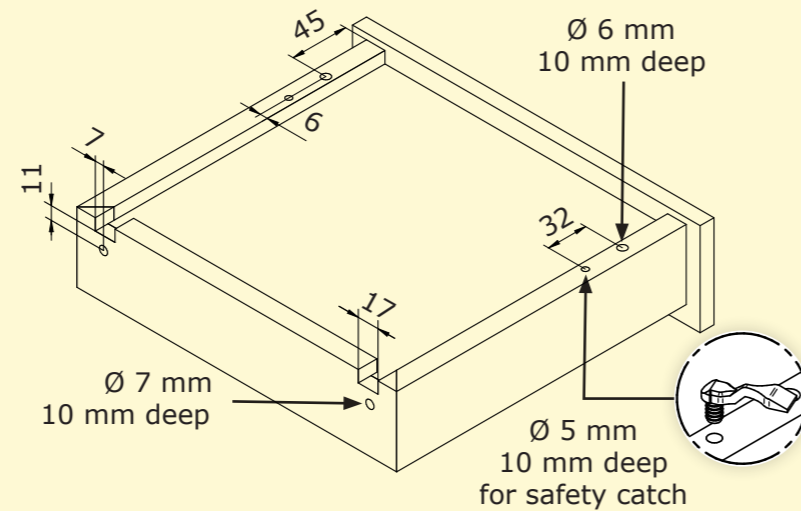

Milling in the cabinet

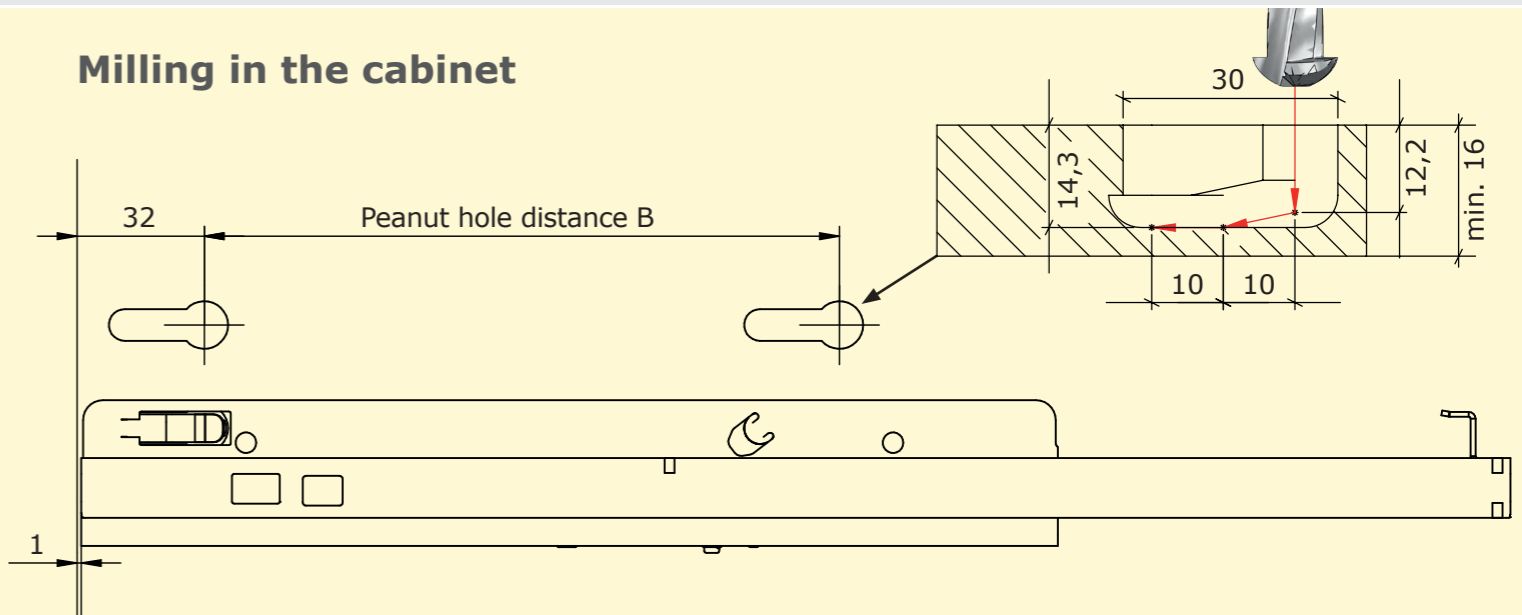

Drawer length in mm	Cabinet runner in mm	Drawer runner in mm	Push-to-Open	Runners/Box	Boxes/Pallet maximum	Pieces/Pallet maximum	Weight/Pallet maximum	Order number left side	Order number right side
250	214	260	x	30	45	1350	468	3212503009000	3222503009000
300	246	310	x	30	35	1050	421	3213003009000	3223003009000
350	246	360	x	30	35	1050	443	3213503009000	3223503009000
400	278	410	x	24	42	1008	489	3214003009000	3224003009000
450	310	460	x	24	42	1008	542	3214503009000	3224503009000
500	342	510	x	24	30	720	420	3215003009000	3225003009000
550	342	560	x	24	30	720	435	3215503009000	3225503009000